

BACK VIEW II SCALE 1:5

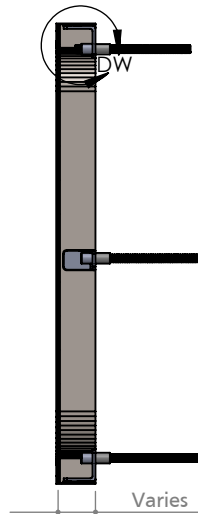

SECTION A-A II SCALE 1:5

Stainless steel Mounting Stud Size varies (see table)

"L" bracket secured with high resistance epoxy to return

Threaded Stud Boss Size varies by bracket

Optional spacer sleeve (Size varies)

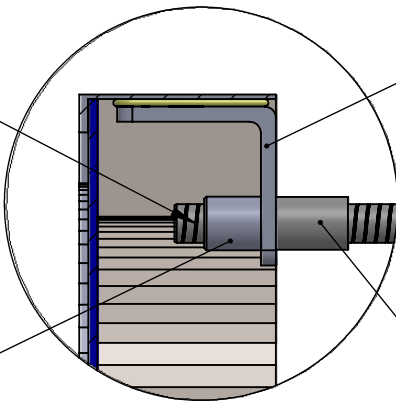

DETAIL DW II SCALE 1:1

Face insert secured with hold-down blocks (see table)

Hold-down blocks secured with high resistance epoxy to outline and return

Stainless steel "L" bracket Size varies (see table)

24 gauge return material - up to 24" high
22 gauge return material - over 24" high

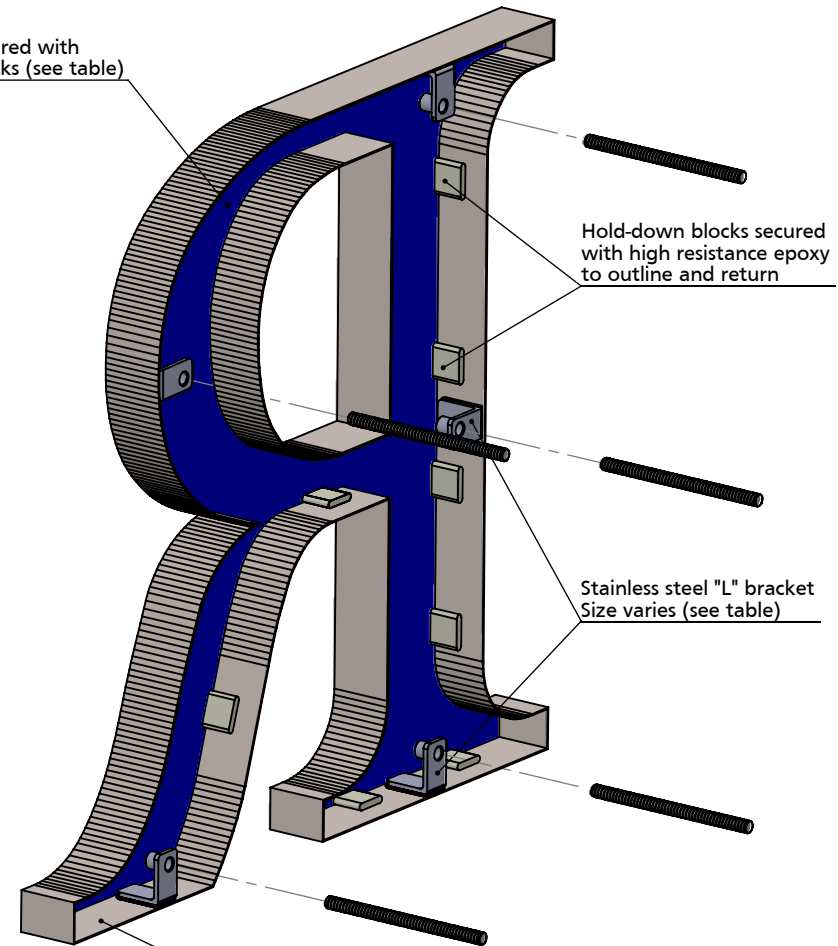

ISOMETRIC BACK VIEW II SCALE 1:3

INSERT OPTIONS	
Stainless steel	18-20 gauge up to 24" high 16-18 gauge over 24" to 36" high
Acrylic	3/16" thick - up to 36" high

LETTER SIZE	MIN. DEPTH AND STROKE	BRACKET	STUD
up to 6"	0.6" 15 mm	Small	6 - 32
over 6" to 24"	1.0" 25.4 mm	Medium	10 - 24
over 24"	1.75" 44.5 mm	Large	1/4 - 20



MATERIAL OPTIONS
Standard - 304 prefinished stainless steel
Optional - 316 prefinished stainless steel (more corrosion resistant)
- 304 prefinished stainless with titanium coating

TITLE:

CUT OUT FACE WITH INSERT-NO BACK - SIDE MOUNT

MATERIAL:

STAINLESS STEEL

PRODUCT TYPE:

FABRICATED METAL

DWG NO. FABL50

REV 10/30/14

SCALE: AS INDICATED

SHEET 1 OF 1